



**OUR POWER, YOUR SATISFACTION**



**DIAMOND SERIES**

Wine Industry pumps

DHE series



### Hopper series

Series with hopper and auger feed screw to convey directly the product to hydraulic part, are the ideal machines for pumping viscous and non-flowing, with a very high solids content.

Version with large eccentric rectangular hopper, auger feed screw, and integrated trolley. Ideal for enological sector in connection with the destemmer, for pumping the crushed grapes or without stalks. Extremely compact construction realized in stainless steel AISI 304 as standard, in all its components.

It is used a worm helical bevel gearbox to optimize the available space. As standard is supplied with welded mesh protection on the hopper, carter for motorization protection and a large handle suitable to implement electrical panel and inverter. Can be supplied with level probe into the hopper for automatic switching off of the pump.

- DHE Series: the drive is integrated directly to the machine construction. Are used Helical bevel worm gear reducers, allow a considerable axial compactness, following the overall dimensions of the eccentric hopper. The gear box is coupled directly to the pump by plug-in shaft to the pump entrance. The protection carter is mounted directly to the hopper to protect the motorization for avoid its tear.

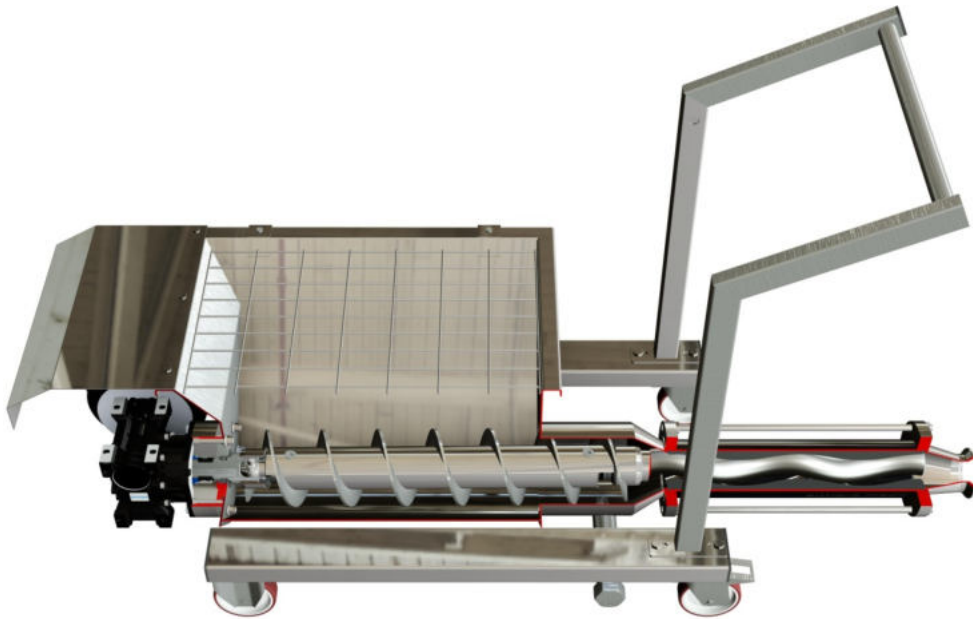

**Patented Pin Joint:** The pin-type joint, the actual heart of the single screw pump, is the best solution of its type on the market. It offers greater duration, reliability and reduced maintenance costs, managing to combine extreme compactness with unrivalled strength. Its particular manufacturing enables the sub-division of axial loads and torque in different elements, making it one of a kind. As well as the above, replacement of worn parts is cheap thanks to the bushes in the worn zones, avoiding costly replacement of parts (rotor, drive shaft, and female drive shaft). To resist high pressure in the pump casing up to 12 bar, the pin can be hydraulically balanced.

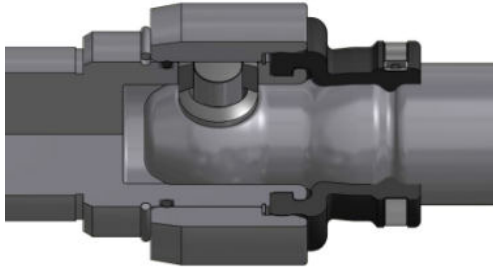

**Trolley:** The hopper structure provides an integrated cart that gives a great strength to the pump. The thicknesses used are superior to any other product on the market. The handle is easily removable in case of any space problems. The wheels are manufactured in stainless steel.

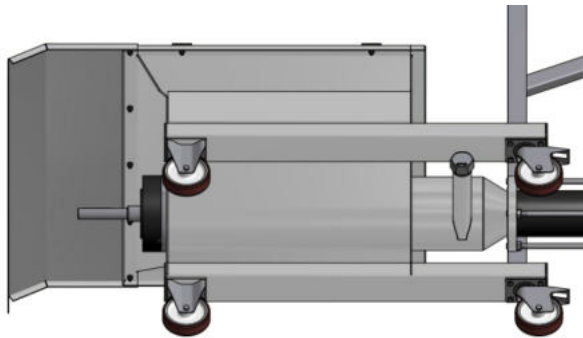

**Performance:** Duration, efficiency, reliability and low consumption. With the Diamond series, we have reached the maximum levels of technological development in every aspect.

**Efficiency:** Maximum performance level, exceptional operating efficiency thanks to the optimum volumetric yield and high pressure and its consumption reduced to a minimum. All the Diamond series hydraulics efficiencies were calculated to guarantee the maximum found on today's market.

**Materials:** All parts in contact with the product of the DHE Diamond Series pumps are in stainless steel AISI 304, as well as other materials on request such as AISI316. Also, in this version the protection devices into the hopper, motorization carter, trolley construction and handling are in stainless steel AISI304. The seals in NBR are foodgrade, suitable for foodstuff contact.

**Low pulsating flows:** Tensional stress and pulsating flow are very low. The centrifugal effect is reduced to a minimum thanks to the low operating speeds and mainly the axial development of the pump.

**Shaft sealing:** In the DHE series two seal system are provided. They are designed specifically for wine applications, to guarantee reliability and ease of maintenance. Both systems are positioned to be easily accessible from the hopper, this permit to avoid stagnation, death zones and high cleanability.

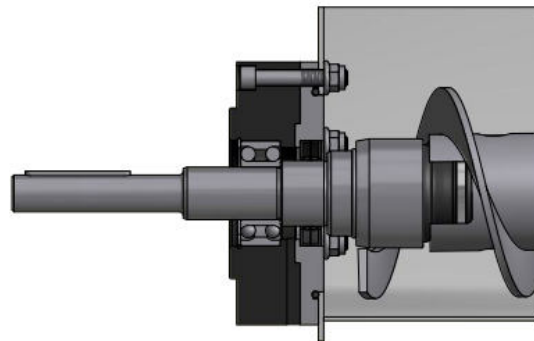
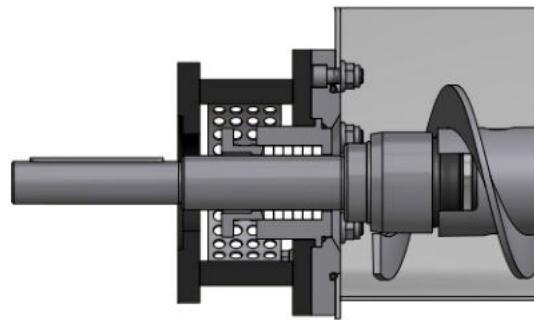

**Versatility:** The Diamond series was designed to be versatile whatever its use. For this reason it can be set up with various options and accessories suitable for every field of application. As well as the above, the peculiar features of the single screw pump are naturally taken advantage of with various types of fluids pumped, from low to the highest viscosity, clean and containing solids varying in size and nature.

**Motorizations:** All the drives which are installed on the Diamond series have been tested for long periods and subject to strict and rigorous technical checks. We can install both electric and hydraulic motors.

All the models of reducers and variators present determined characteristics in terms of strength, size of the bearings and the quality of the gears.

**Quality** Each part is manufactured according the highly restrictive quality specifications. Finishes and precision of each part are the basis of each pump manufactured. All parts are subject to specific controls based on their characteristics and functionality.

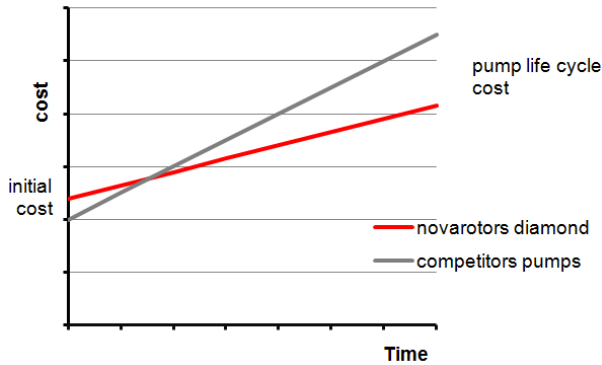

**Maintenance:** The Diamond series is designed to ensure easy maintenance and normally require the replacement of a minimum number of components.

In particular the joint bushes allow the replace of the same without having to replace shafts and rotors.

The costs of maintenance are really reduced. The cost of the pump, considered in his full life cycle, is highly competitive.

**Cost / benefit :** The Diamond series, thanks to the compactness of its elements combined technical success without comparison at very competitive costs. The modularity allows you to make the right solutions depending on the application to avoid paying for features you do not need, all in favor of its competitiveness.

**Self-priming:** The peculiarities of the hydraulic parts of the progressive cavity pump allow excellent self-priming (up to 7m). The Diamond series were designed to create the minimum loss possible in the pump body, thanks to large sections and a joint compact design and fluid dynamic.

**Ease of installation:** The pumps of the Diamond series are easy to install due to compactness, simplicity of operation and operational flexibility thanks to the various features included.

**Detailed documentation:** Each pump comes with clear and detailed operating instructions. Orders are followed by experienced and qualified staff that integrates in providing detailed documentation on demand and specific for the product supplied.

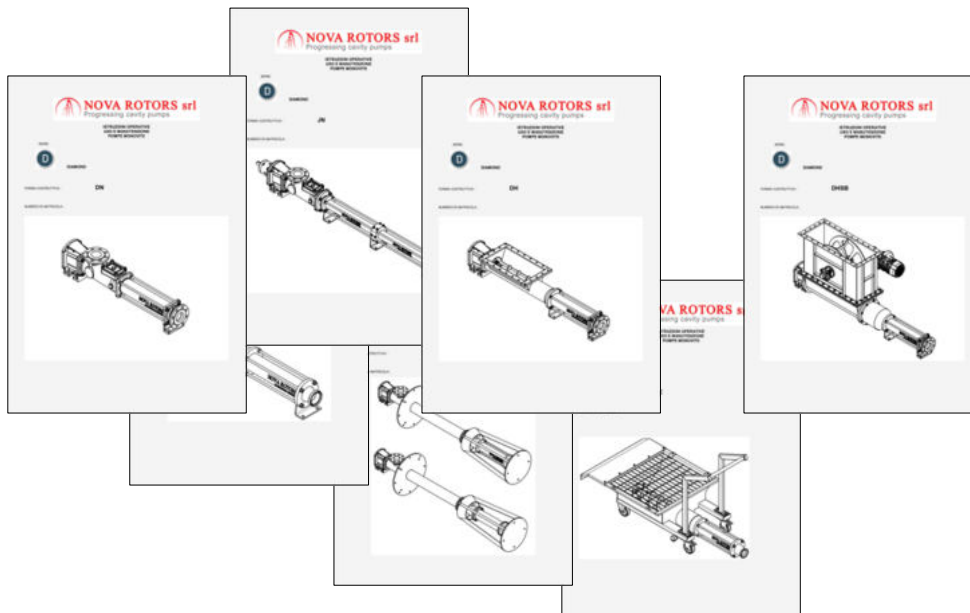

## Detailed characteristics

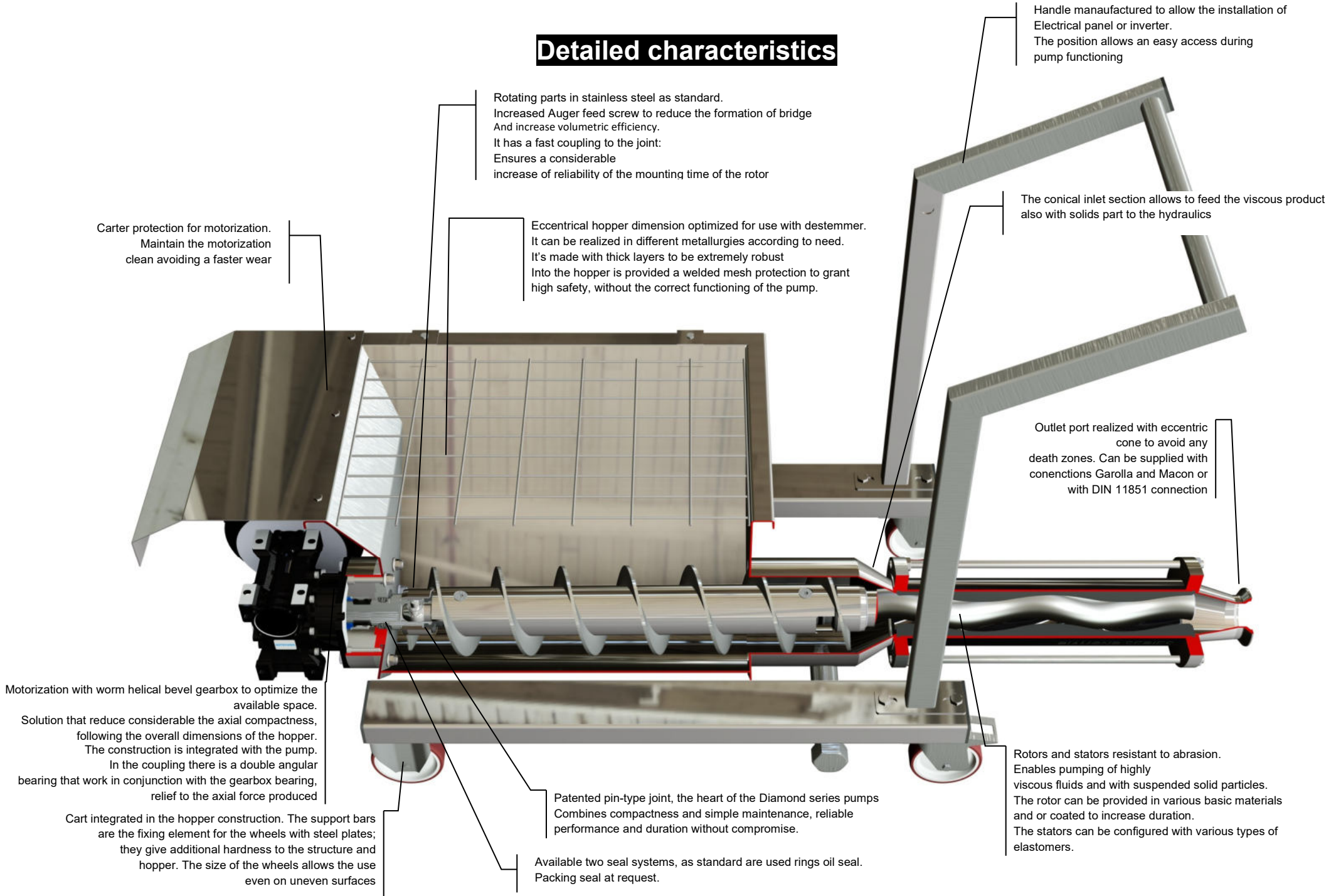

## VERSION AND OPTION

### Casing material

#### Base materials:

AISI 304 (AISI 316 on request)

### Materials of the sealing shaft

#### Base materials:

AISI 304 (AISI 316 on request)

#### Coatings:

Chrome oxide plasma (ceramic coating)

### Rotor material

#### Base materials:

AISI 304 (AISI 316 on request)

#### Coatings:

Chrome oxide plasma (ceramic coating)

### Stator material

#### Base materials:

NBR, food grade NBR, white NBR food grade  
EPDM, EPDM food grade, white EPDM food grade  
FPM, FPM food grade  
HNBR, HNBR food grade  
SYLICON  
Buna-N (available on select models on request)  
HYPALON (available on select models on request)  
PTFE (available on select models on request)

### Base plates

Trolley (cart) with handle integrated on the hopper construction  
(For details, see the brochure constructive options, equipment and installations)

### Connections

Garolla  
Macon  
DIN 11851  
Clamp ISO 2852, Clamp ASME-3A, Clamp DIN 32676  
RJT  
SMS 1145

### Sealing system

Lip seal  
Gland packing seal B01  
(For construction details, see the brochure sealing systems and seals)

### Optional for coupling rod

Joint protection  
Coupling rod with feed screw  
(For details, see the brochure constructive options, equipment and installations)

### Protection devices

Temperature probe for dry running protection  
Flow switch  
Pressure switch  
(For details, see the brochure constructive options, equipment and installations)

### Control devices

Control panel  
Control panel with inverter  
Drive with integrated inverter  
(For details, see the brochure constructive options, equipment and installations)

### Equipment and optional

Eccentric Outlet  
(For details, see the brochure constructive options, equipment and installations)

### Certifications

CE  
ATEX

## FEATURES OF USE

### Operating range

#### Flow

Up to 315m<sup>3</sup>/h

#### Pressure

Up to 6 bar for the standard series (12 bar on request)

#### Temperature

from -40°C until to 150°C

### Typical applications

Crushed grapes with or without stalk

Wine lees

Pomace

Must

Grapes

## TABLE OF MODELS

### Flow and pressure

Size	Model	Qmax 2 bar [m <sup>3</sup> /h]	rpm max	P max [bar]
<b>D020</b>	1L1	4,9	1400	6
	05K2	2,5	1400	12
<b>D025</b>	2L1	6,9	1000	6
	1K2	9,4	1000	12
<b>D030</b>	4L1	11	800	6
	2K2	5,6	800	12
<b>D040</b>	10L1	16,5	600	6
	4K2	8,5	600	12
	16L1	23,5	600	6
	8K2	12	600	12
<b>D060</b>	20L1	28	500	6
	10K2	14	500	12
	30L1	33	500	6
	16K2	16,5	500	12
<b>D120</b>	40L1	43	400	6
	20K2	20	400	12
	60L1	63,5	400	6
	30K2	32	400	12
<b>D300</b>	80L1	76	350	6
	40K2	38	350	12
	120L1	110	350	6
	60K2	55	350	12
<b>D400</b>	160L1	140	350	6
	80K2	78	350	12
	240L1	230	350	6
	120K2	115	350	12
<b>D500</b>	320L1	220	300	6
	160K2	120	300	12
	480L1	315	300	6
	240K2	155	300	12





Via Carlo Cattaneo, 19/25  
36040 SOSSANO (VI)  
ITALY

Telefono: +39-0444-888151  
Fax: +39-0444-888152  
Mail: [info@novarotors.com](mailto:info@novarotors.com)  
Sito web: [www.novarotors.com](http://www.novarotors.com)

