



OUR POWER, YOUR SATISFACTION

OLIVE OIL INDUSTRY



OLIVE OIL INDUSTRY



Olive oil is one of our most familiar, widely used products as it is the basis of the traditional Mediterranean cuisine.

Olive oil cultivation and production techniques have origins dating back to Ancient Grecian times, subsequently adopted by the Romans who exported it to most of Europe as we know it today.

Nowadays, the oil industry is widespread throughout Italy and countries such as Greece, France and Spain where favourable climatic conditions for olive growing prevail. The last century saw a shift from small-scale artisanal production, operated by the actual owners of the olive groves, to major industrial plants. The industry has invested in new processing techniques to constantly improve product quality, as well as to increase output.

Progressive cavity pumps perform best in the various process stages, as they convey the fluid throughout the entire process in a particularly delicate way, from grinding of the olives through to bottling of the oil. The tensile stress to which the pumped fluid is subjected is very limited compared to other pumping systems, being pulsation-free, above all with heterogeneous products such as for example the paste produced after the first grinding step. Integration of the pumps with the different processing machines ensures fast transfer times which is indispensable for the preservation of the organoleptic characteristics of the product needed to achieve a high quality oil.

WHY CHOOSE NOVA ROTORS?

Nova Rotors has worked in the olive oil industry for many years seeking to provide the best possible solutions, a wide range of products, services and experts to find the most suitable configuration based on the customer's specific requirements. The various testimonials received from our customers around the world over the years attest to the commitment of a dynamic company focussed on meeting the constantly growing market demands.

The pumps conceived and developed directly by Nova Rotors are designed specifically for pumping olive must, olive paste and olive pomace, all products containing a high percentage of solids content. In particular, special attention has been given to the choice of materials that come into contact with the product and of the various elastomers, selected only after extensive testing in order to guarantee excellent machine performance, reliability and duration.

Nova Rotors progressive cavity pumps developed scrupulously in compliance with the strictest hygiene standards, guarantee high standards of quality, reliability and duration, by providing the best solutions throughout the entire production process. In particular special attention has been given to each transition from one process stage to the next, by making various construction types available in order to optimise each transfer.



DN
Flanged Industrial Pump to pump olive paste for the treatment and working stage in the olive oil mill.

FLOW CHART

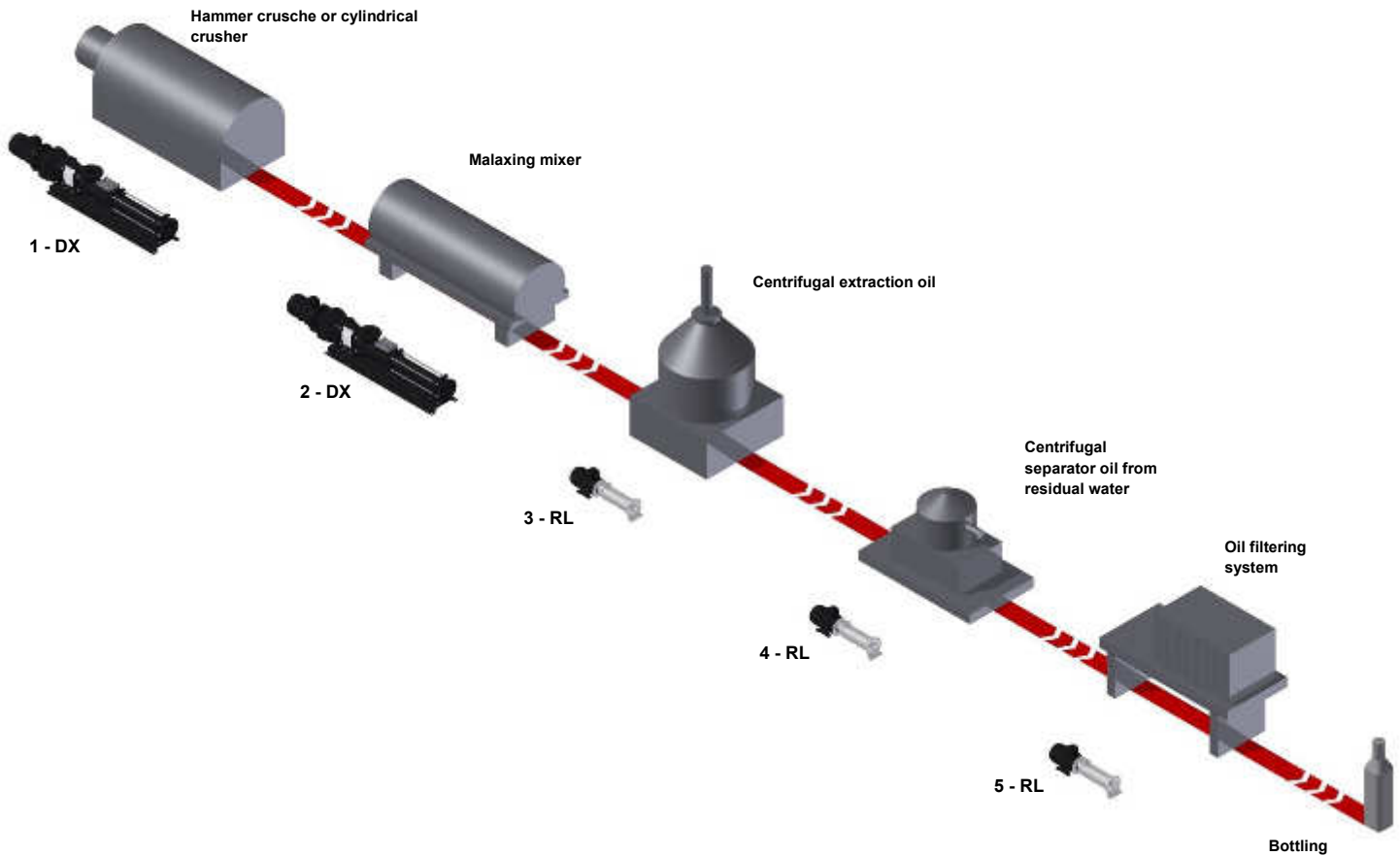

Application (refer to above diagram):

1. **DX:** pump designed specifically for the food industry, used to transfer the product from the hammer crusher to the next step, malaxation of the paste consisting of solid fragments of pits, skins and pulp obtained after milling
2. **DX:** pump used to transfer the olive paste, after the malaxation process, to the centrifuge where the oil is separated from the water.
3. **RL:** wobble pump used for pumping the oil must as it flows from the centrifuge that separates it from the pomace, which is the solid part of the olive paste, and then passes to the next stage which is separation of the oil from the residual water.
4. **RL:** pump designed to pump oil obtained from the separation stage (oil from the residual water) to the filtering stage
5. **RL:** pump designed to pump filtered oil to the bottling stage

Product for olive oil sector

DN SERIES

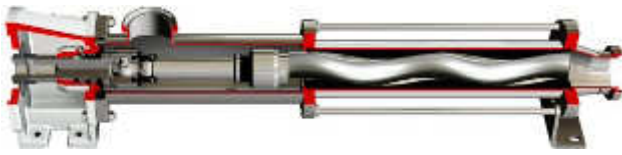

Industrial series ideal for heavy duty applications with foodgrade connections.
It is the best solution for the industrial sector for pumping a vast range of fluids; available with UNI, DIN and ANSI flanged and GAS BSP threaded connections in stainless steel AISI 304 or AISI 316.

DH SERIES

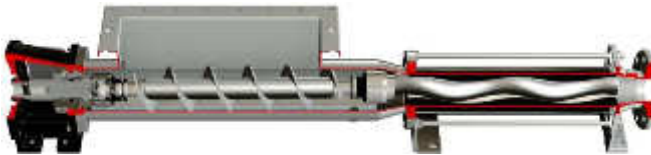

Standard model equipped with hopper and auger feed screw to move the product to the hydraulic part. Suitable for pumping materials with a low degree of flowability and prone to bridging.

RL SERIES



The RL series is an extremely compact product thanks to the integrated pump-electric motor construction. The patented pin joint of the Diamond series ensures high reliability.

R SERIES



The R series is the most compact product available due to the elimination of the block between the pump and the drive. It uses a double pin joint, is reliable and easy to maintain.

APPLICAZIONI

DN pump

DN pump used for transferring of pulp/olive paste from malaxer mixer to decanter to separate solid dregs and sediment to the oil



RL pump

RL pump used to transfer the Virgin olive oil.

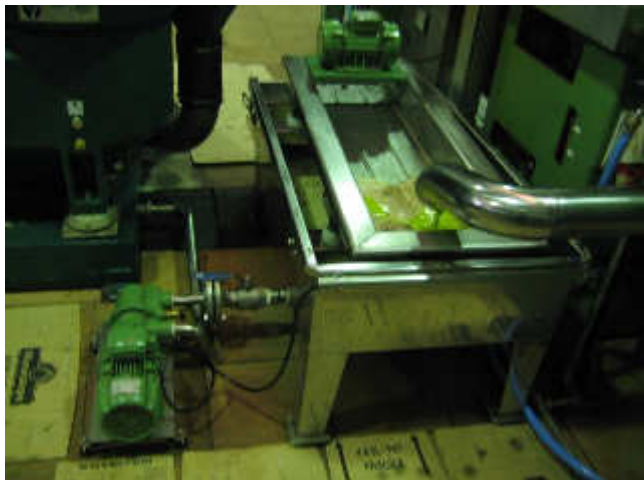

Pump R

Pump type R series with wobble stator for pumping vegetables waters.



Via Carlo Cattaneo, 19/25
36040 SOSSANO (VI)
ITALY

Telefono: +39-0444-888151
Fax: +39-0444-888152
Mail: info@novarotors.com
Sito web: www.novarotors.com



ISO 9001: 2008
No.:2011/1353
OHSAS 18001:2007
No.:2010/915



CEC 07 ATEX 110 -
REV.1