

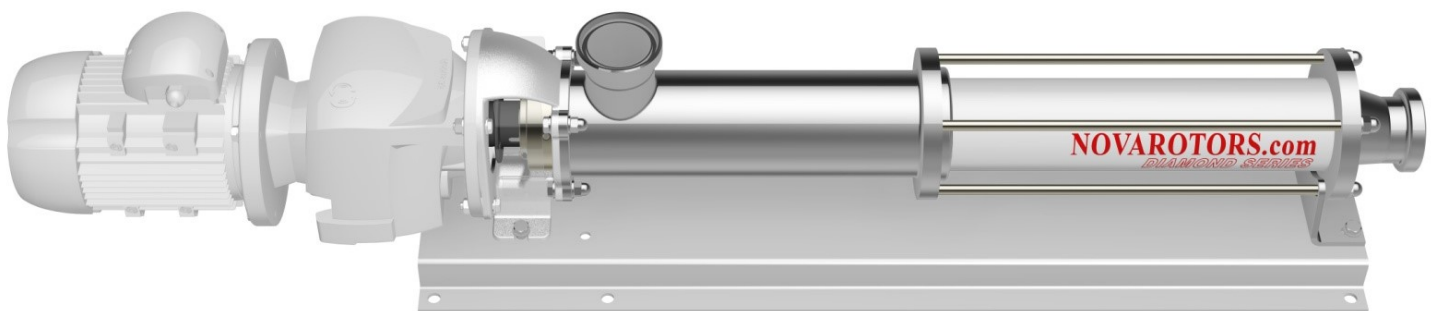

**OUR POWER, YOUR SATISFACTION**



**DIAMOND SERIES**

Sanitary pumps

DX / JX / FX / DHX / JHX / FHX series



### DX Hygienic Series

The DX hygienic pump series is state of the art for the food, pharmaceutical, chemical and cosmetic industries. The complete sanitary design, in compliance with standards EHEDG and 3A, ensures maximum sanitization. These pumps are top rated for " Clean In Place" and " Sterilizing In Place". The geometry of the pumps is designed specifically to allow drainage and avoid dead zones. Each component is manufactured with the highest level of finish and utmost cleanliness.

As well as the parts that come in contact with the product, the block and base plate (when requested) are made of stainless steel (standard in AISI 304).

The available fittings include DIN 11851, DIN 11864, Clamp ISO 2852, Clamp ASME-3A, Clamp DIN 32676, RJT, SMS 1145 and lastly Garolla and Macon for the wine industry.

The complete range of pumps can be manufactured with block construction (DXO SERIES and DXC SERIES), bearing housing with independent shaft (JXO SERIES and JXC SERIES) or bearing unit with plug-in shaft (FXO SERIES and FXC SERIES).

- **DX Series:** the drive is coupled directly to the pump via a flange. This solution is extremely cost effective and compact, considerably reducing installation costs and simplifying maintenance. The forces generated by the hydraulic part are supported by the drive itself. Each drive used is adequately selected based on their specific technical parameters and are subject to numerous duration tests with heavy loads.

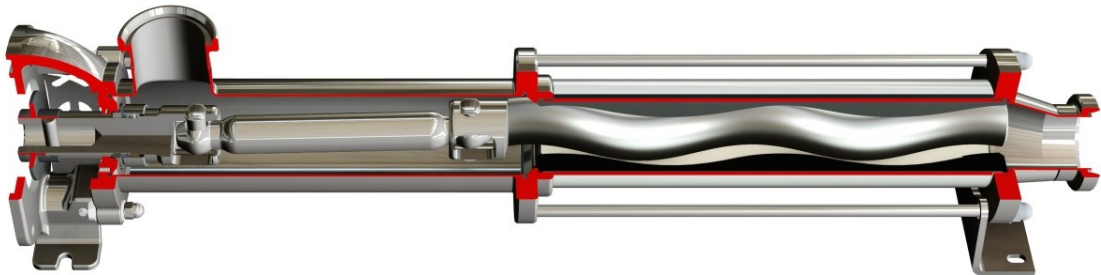

- **JX Series:** the drive is connected to the shaft inlet via a flexible coupling. This configuration is the best solution in terms of performance and durability. All the forces generated by the pump are absorbed by the bearings in the housing. These bearings have very high resistance against loads. They are assembled with extreme precision on the highest quality manufactured parts. It is the best solution when you want to guarantee duration and reliability, yet with greater installation space requirements. The bearing unit designed by us is modular and can be adapted to a DX Series pump with lantern. It is state of the art for this type of installation.

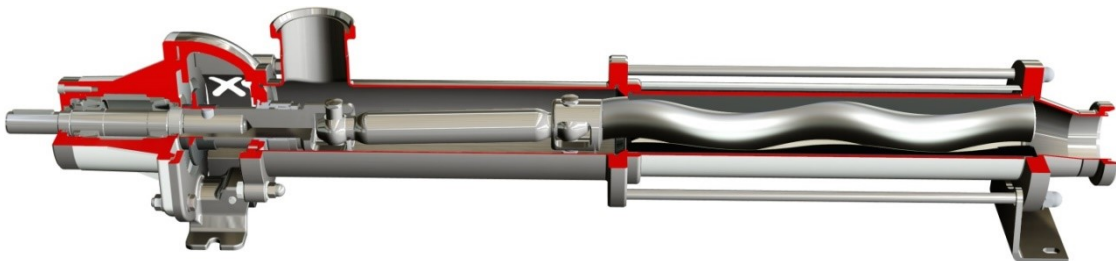

- **FX Series:** the drive is connected directly to the pump via a flange of the modular bearing unit. This is the most versatile solution because it allows to use gearbox with flange and standard output shaft, the connection with hydraulic and pneumatic motors, by keeping the simplicity and the compactness of the classic coupling flange solution and at the same time it ensures total reversibility and higher performance of the bearing unit. This modular bearing unit can be applied on all the Diamond series pumps and it allows a quick maintenance of the drive. FX is synonym of modularity and reliability with any kind of drive.

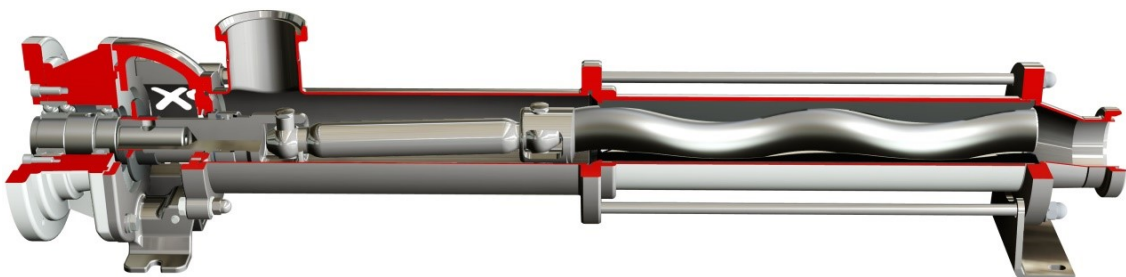

- DXO serie:** the DXO series is a hygienic pump with open joint. It is the solution with the best sanitisation characteristics thanks to the design of the casing and the rotating parts completely free of dead zones and stagnation. The pin-type joint has been suitably sized to guarantee long duration. Lubrication of the joint is guaranteed by the product thanks to its open design, therefore it is suitable for non-abrasive fluids. Performance improves considerably when pumping lubricant products.

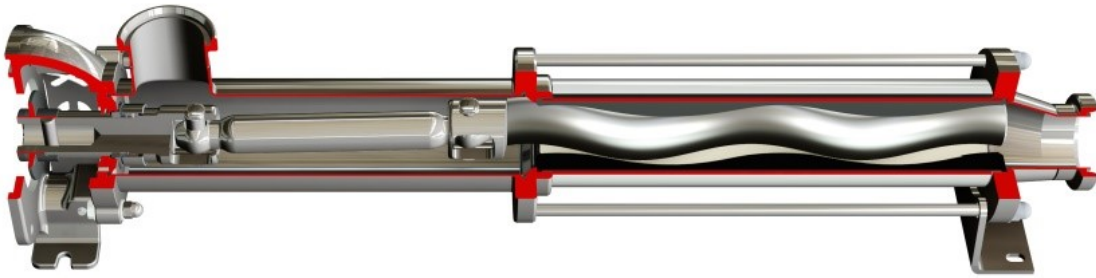

- DXC serie:** the DXC series is a hygienic pump with pin, standard to the DN series. This solution combines excellent sanitisation characteristics thanks to the design and casing completely free of dead zones and stagnation, together with the performance of the pin-type joint patented in the Diamond series. Lubrication of the pin is independent of the pumped product, therefore it is also suitable for abrasive fluids.

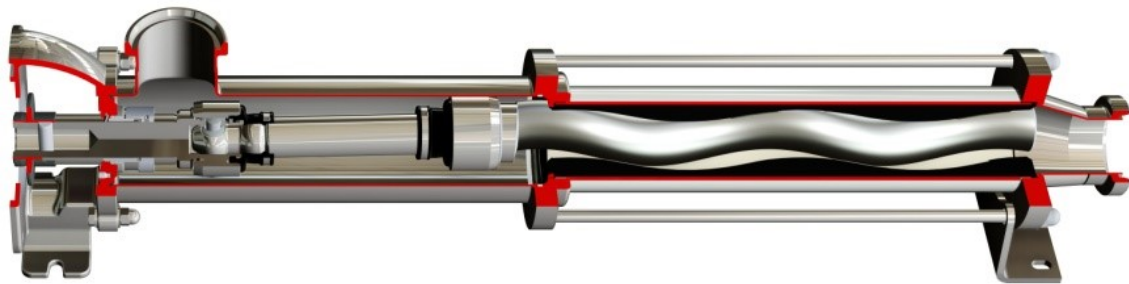

- DXO serie EHEDG design:** the DXO serie is designed according to EHEDG (European Hygienic Equipment Design Group) regulation. The sanitary open pin transmission is the best sanitification solution in cleaning cycle phase. The pump guarantee the inside cleaning by cleaning in place, respect the standard DXO, reduced up to 35% of quantity of cleaning agent used during the cleaning cycle getting an economic saving. Lower flow rate to cleaning in place is lower chemical product using and is lower stress hydraulic components (in special the stator) therefore greater during the components.

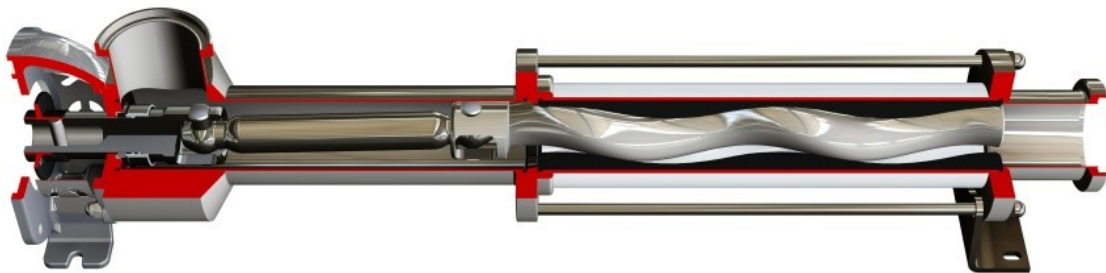

### DHX Hygienic Series

The DHX hygienic pump series with hopper an auger feed screw to convey directly the product to hydraulic part, is the ideal machines for pumping viscous and non-flowing, with a very high solids content. Suitable for pumping substances poorly flowing up to 18% of dry substance which does not tend to form a bridge.

The complete sanitary design, in compliance with standards EHEDG and 3A, ensures maximum sanitization. These pumps are top rated for "Clean In Place" and "Sterilizing In Place". The geometry of the pumps is designed specifically to allow drainage and avoid dead zones. Each component is manufactured with the highest level of finish and utmost cleanliness.

As well as the parts that come in contact with the product, the block and base plate (when requested) are made of stainless steel (standard in AISI 304).

The available fittings include DIN 11851, DIN 11864, Clamp ISO 2852, Clamp ASME-3A, Clamp DIN 32676, RJT, SMS 1145 and lastly Garolla and Macon for the wine industry.

The complete range of pumps can be manufactured with block construction (DHXO SERIES and DHXC SERIES), bearing housing with independent shaft (JHXO SERIES and JHXC SERIES) or bearing unit with plug-in shaft (FHXO SERIES and FHXC SERIES).

- **DHXO serie:** the DHXO series is a hygienic hopper pump with open joint. It is the solution with the best sanitisation characteristics thanks to the design of the casing and the rotating parts completely free of dead zones and stagnation. The pin-type joint has been suitably sized to guarantee long duration. Lubrication of the joint is guaranteed by the product thanks to its open design, therefore it is suitable for non-abrasive fluids. Performance improves considerably when pumping lubricant products.

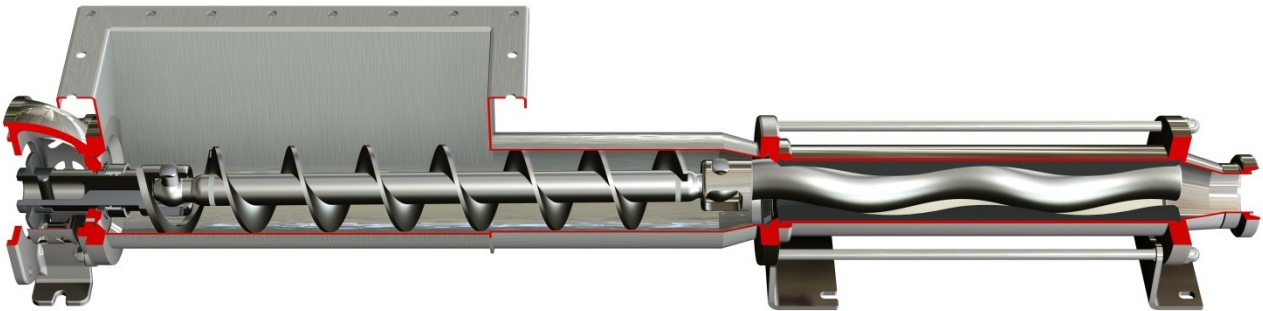

- **DHXC serie:** the DHXC series is a hygienic hopper pump with pin, standard to the DN series. This solution combines excellent sanitisation characteristics thanks to the design and casing completely free of dead zones and stagnation, together with the performance of the pin-type joint patented in the Diamond series. Lubrication of the pin is independent of the pumped product, therefore it is also suitable for abrasive fluids.

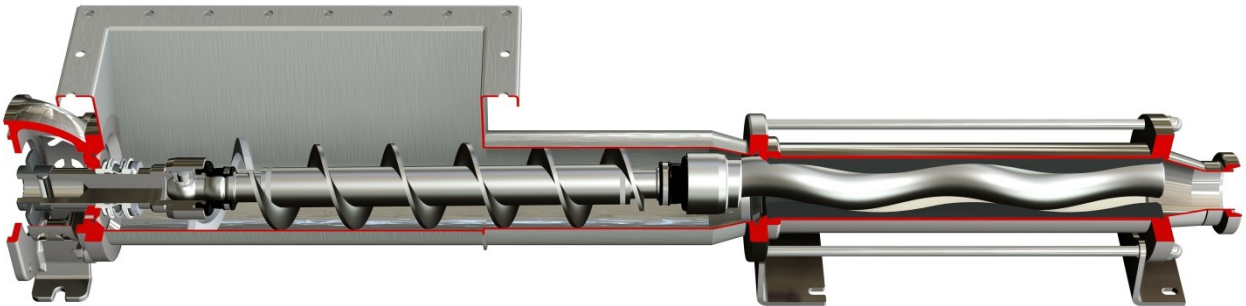

**Patented Pin Joint (DXC Series):** the pin-type joint, the actual heart of the single screw pump, is the best solution of its type on the market. It offers greater duration, reliability and maintenance costs, managing to combine extreme compactness with unrivalled strength. Its particular manufacturing enables the sub-division of axial loads and torque in different elements, making it one of a kind. As well as the above, replacement of worn parts is cheap thanks to the bushes in the worn zones, avoiding costly replacement of parts (rotor, drive shaft, and female drive shaft). To resist high pressure in the pump casing up to 12 bar, the pin can be hydraulically balanced.

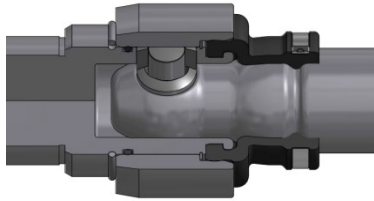

**Open Joint (DXO Series):** open joint with superior sanitation characteristics. Lubrication is guaranteed of the pumped product thanks to the mechanical geometry that enables direct entry in contact with the sliding parts. This joint is particularly strong thanks to the dimensions designed to ensure its performance despite the lack of lubrication with specific products. The biggest benefit counts in its fast maintenance, for assembly and dismantling there is no need for any tool or product for sealing or lubricant. Replacement is cheap and extremely fast.

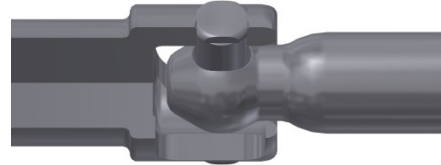

**CFD analysis:** the x sanitary series is designed to guarantee the maximum sanitation inside casings. Using the computational fluid dynamic CFD was optimized the internal design of the machines by checking the turbulence and washing rates based on the correct flow rate during the sanitation cycle.

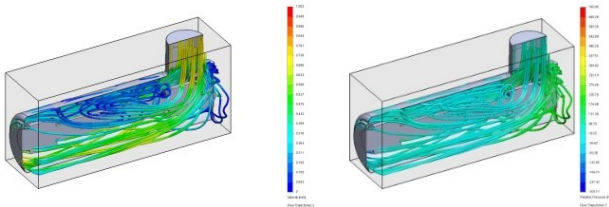

**FEM calculation:** the structural components of X series sanitary pumps are designed by the finite element method FEM. The geometries refine to have optimize the weight and the cost of each component.

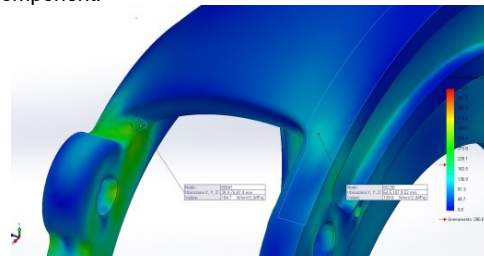

**Versatility:** the Diamond series was designed to be versatile whatever its use. For this reason it can be set up with optionals and accessories suitable for every field of application. As well as the above, the peculiar features of the single screw pump are naturally taken advantage of with various types of fluids pumped, from low to the highest viscosity, clean and containing solids varying in size and nature.

**Materials:** the parts in contact with the product of the Diamond DXC and DXO series pumps can be in stainless steel (AISI 304 e AISI 316), on request in other materials such as Duplex and Super Duplex. All parts have excellent finishes and the casings are polished to ensure utmost sanitation of the surfaces.

**Base plates:** the base plates are characterized by considerable thicknesses are very strong. They are made in stainless steel as standard. They can be provided with hygienic housing, with adjustable anti-vibration, in the trolley version or on skids, based on the client's specifications.

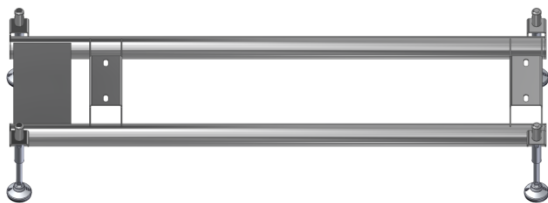

**Shaft sealing:** different sealing systems can be installed, each solution being suitable to specific usage. The types available are: single acting mechanical seal, with quench, double acting mechanical seal back to back or tandem. The type of seals are all interchangeable on the standard pump. Each solution was carefully engineered while taking into consideration all the operating conditions. You can also install various types of mechanical seals based on the application. The inner seals are in the advanced position for greater coverage of the pumped product, promoting its duration and cleaning.

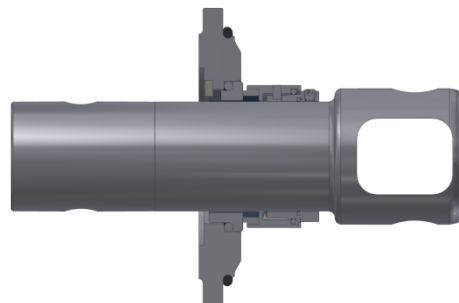

**Low pulsating flows:** tensional stress and pulsating flow very low. The effect of the centrifuge is reduced to the minimum thanks to the low operating rotations and the mainly axial development of the pump.

**Performance:** duration, efficiency, reliability and low consumption. With the Diamond series, we have reached the maximum levels of technological development in every aspect.

**Modularity:** the Diamond series is based on the concept of modularity in every characteristic: hydraulic parts, casing, seals, base plates, housing, drive shafts. Each part can be manufactured in a series of variants without changing the structure of the machine, while keeping the main spare parts standard.

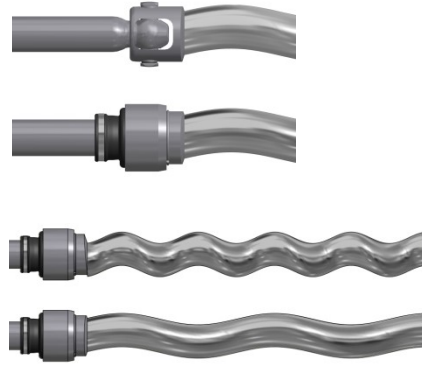
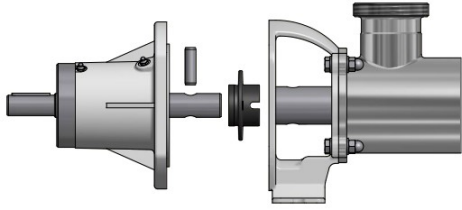

**Efficiency:** maximum performance level, exceptional operating efficiency thanks to the optimum volumetric yield and high pressure and consumption reduced to the minimum. All the Diamond series hydraulics were calculated to guarantee the maximum found on today's market.

**Motorizations:** all the drives which are installed on the Diamond series have been tested for long periods and subject to strict and rigorous technical checks. We can install both electric and hydraulic motors. All the models of reducers and variators present determined characteristics in terms of strength, size of the bearings and the quality of the gears.

**Quality** each part is manufactured according the highly restrictive quality specifications. Finishes and precision of each part are the basis of each pump manufactured. All parts are subject to specific controls based on their characteristics and functionality.

**Maintenance:** the Diamond series is designed to ensure easy maintenance and normally require on the replacement of a minimum number of components . In particular the joint bushes allow the replace of the same without having to replace shafts and rotors. The costs of maintenance are really reduced . The cost of the pump, considered in his full life cycle , is highly competitive .

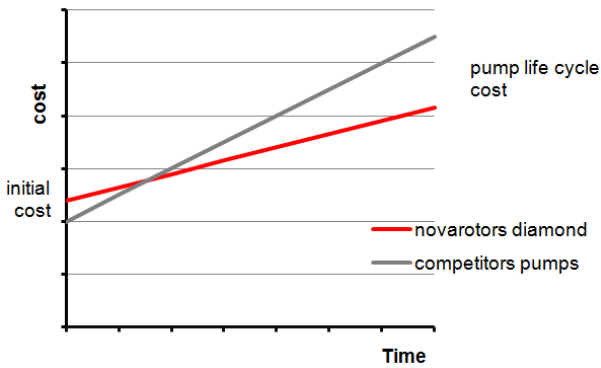

**Cost / benefit :** the Diamond series , thanks to the compactness of its elements combined technical success without comparison at very competitive costs . The modularity allows you to make the right solutions depending on the application to avoid paying for features you do not need , all in favor of competitiveness

**Selfpriming:** the peculiarities of hydraulic parts of the progressive cavity pump allow excellent selpriming ( up to 7m ) . The Diamond series were designed to create the minimum loss possible in the pump body , thanks to large sections and a joint compact design and fluid dynamic .

**Ease of installation:** the pumps of the Diamond series are easy to install due to compactness, simplicity of operation and operational flexibility thanks to the various features included.

**Detailed documentation:** each pump go with clear and detailed operating instructions. Orders are followed by experienced and qualified staff that integrates in providing detailed documentation on demand and specific for the product supplied.

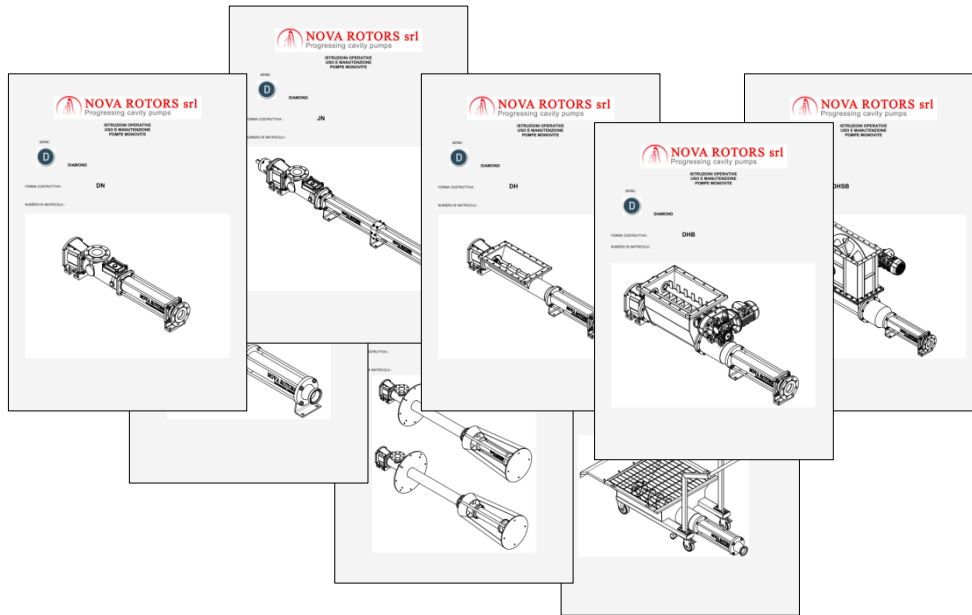

# Detailed characteristics

Lantern manufactured as standard in stainless steel  
Extremely strong and designed for easy cleaning

Ample suction sections enable excellent drying capacity and makes pumping of viscous substances efficient.  
Design free of dead zones or stagnation points.  
Polished casing for improved cleaning in CIP and SIP phases  
Foodstuff fittings DIN 11851, DIN 11864 or Clamp ISO, ASME, DIN as standard

Rotating parts in stainless steel Each part has a highly precious finish to improve sanitisation Various drive shaft options based on needs

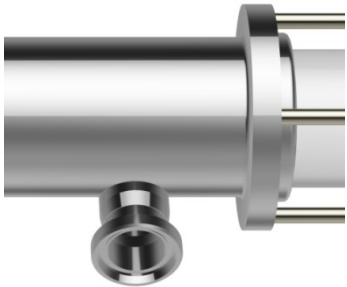

CIP connection built into pump body. This option enables insertion of washing fluid in the pump body to clean hygienic pumps in the best way possible. Manufactured tangential to the body, it avoids stagnation and enables efficient drainage of the fluids.

Output sections suitable for reduced load loss  
Eccentric cone to avoid dead zones or stagnation points. Polishing improves cleaning in CIP and SIP phases  
Foodstuff fittings DIN 11851, DIN 11864 or Clamp ISO, ASME, DIN as standard

The stator funnel is manufactured with rounded geometry to avoid deposits contaminating the product.

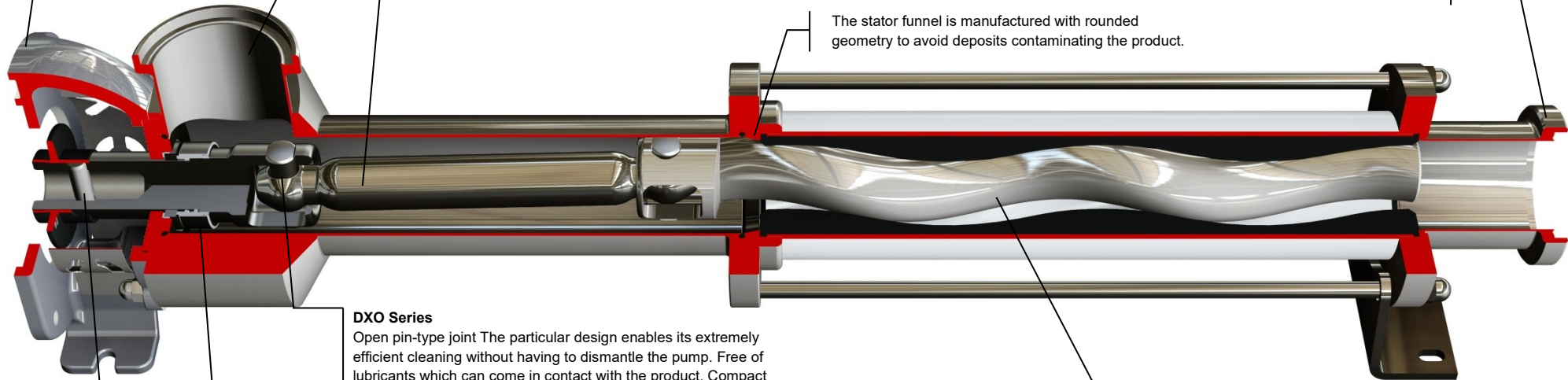

**DXO Series**  
Open pin-type joint The particular design enables its extremely efficient cleaning without having to dismantle the pump. Free of lubricants which can come in contact with the product. Compact and extremely strong, it is the best solution for those requiring maximum sanitisation.

Various seal systems available, including:  
inner single mechanical seal with and without quench, internal and external single mechanical seal, double back to back and tandem mechanical seals  
The position of the seal is advanced for maximum transfer of the product flow. This improves the duration of the seal thanks to the greater convection that facilitates cooling. Product stagnation on the seal is avoided.  
The quench and double seals should be driven by seal supply systems, suitable for the process, also API compliant upon request.  
It is also possible to install a vast range of seals according to standard ISO EN 12756 to meet every application need.

Connection via the pin to the drive or the bearing unit  
The simplest solution for maintenance and enables inverse rotation of the pump The splash ring protects the drive shaft against corrosion, further easing maintenance

Rotors and stators resistant to abrasion.  
Enables pumping of highly viscous fluids and with suspended solid particles.  
The rotor can be provided in various basic materials and thermally treated or coated to increase duration.  
The stators can be configured with various types of elastomers

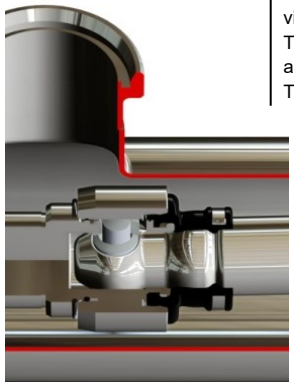

**DXC Series**  
Patented pin-type joint, the heart of the Diamond series pumps  
Combines compactness, simple maintenance, performance, reliability and duration without compromise

## Detailed characteristics

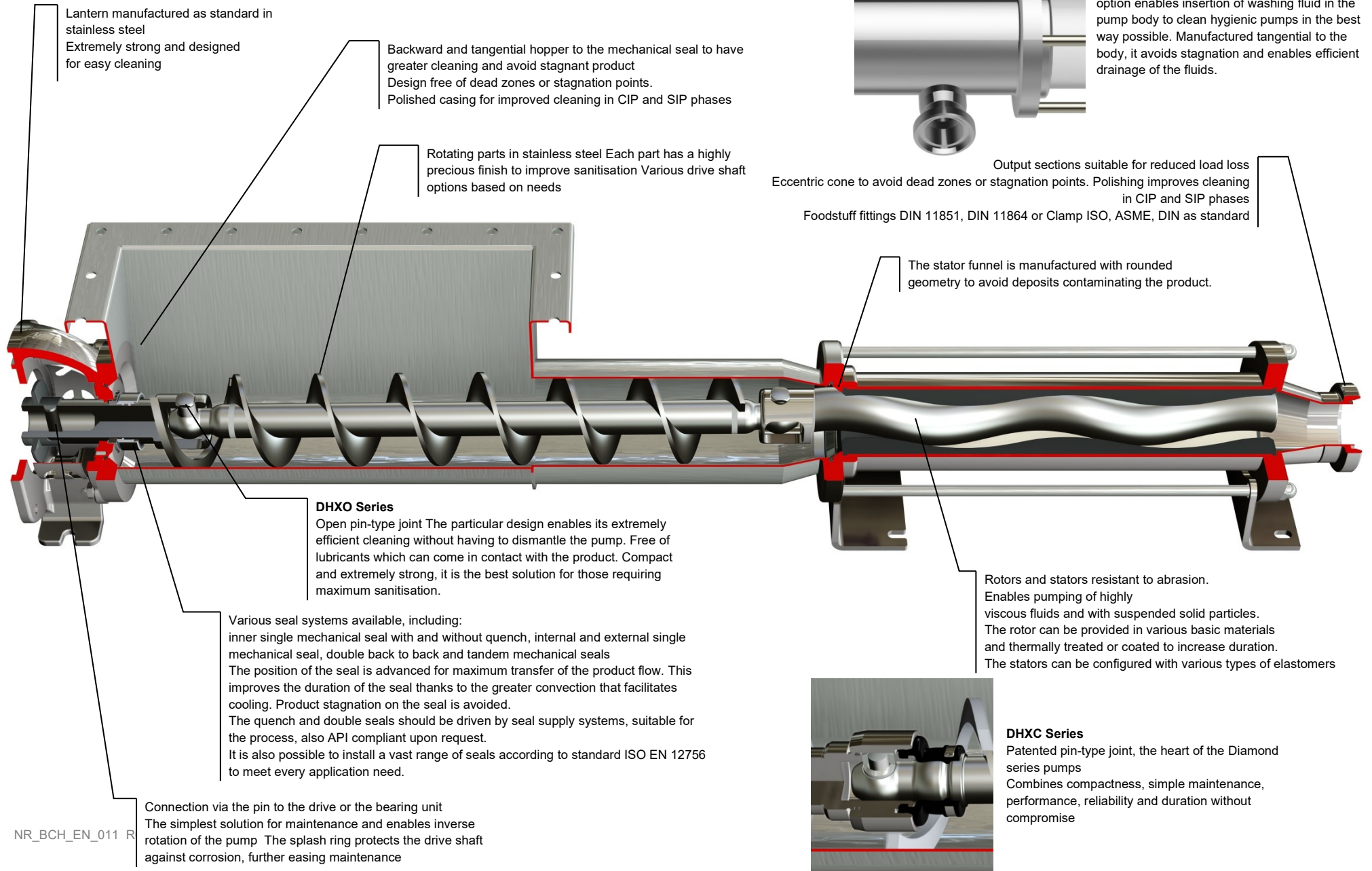

Lantern manufactured as standard in stainless steel  
Extremely strong and designed for easy cleaning

Backward and tangential hopper to the mechanical seal to have greater cleaning and avoid stagnant product  
Design free of dead zones or stagnation points.  
Polished casing for improved cleaning in CIP and SIP phases

Rotating parts in stainless steel Each part has a highly precious finish to improve sanitisation Various drive shaft options based on needs

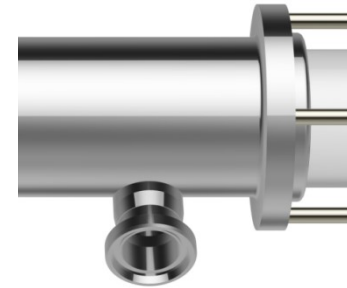

CIP connection built into pump body. This option enables insertion of washing fluid in the pump body to clean hygienic pumps in the best way possible. Manufactured tangential to the body, it avoids stagnation and enables efficient drainage of the fluids.

Output sections suitable for reduced load loss  
Eccentric cone to avoid dead zones or stagnation points. Polishing improves cleaning in CIP and SIP phases  
Foodstuff fittings DIN 11851, DIN 11864 or Clamp ISO, ASME, DIN as standard

The stator funnel is manufactured with rounded geometry to avoid deposits contaminating the product.

### DHXO Series

Open pin-type joint The particular design enables its extremely efficient cleaning without having to dismantle the pump. Free of lubricants which can come in contact with the product. Compact and extremely strong, it is the best solution for those requiring maximum sanitisation.

Various seal systems available, including:  
inner single mechanical seal with and without quench, internal and external single mechanical seal, double back to back and tandem mechanical seals  
The position of the seal is advanced for maximum transfer of the product flow. This improves the duration of the seal thanks to the greater convection that facilitates cooling. Product stagnation on the seal is avoided.  
The quench and double seals should be driven by seal supply systems, suitable for the process, also API compliant upon request.  
It is also possible to install a vast range of seals according to standard ISO EN 12756 to meet every application need.

Rotors and stators resistant to abrasion.  
Enables pumping of highly viscous fluids and with suspended solid particles.  
The rotor can be provided in various basic materials and thermally treated or coated to increase duration.  
The stators can be configured with various types of elastomers

### DHXC Series

Patented pin-type joint, the heart of the Diamond series pumps  
Combines compactness, simple maintenance, performance, reliability and duration without compromise

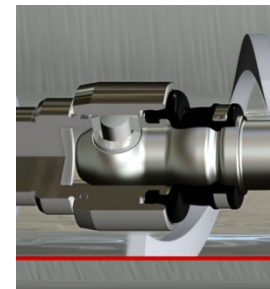

Connection via the pin to the drive or the bearing unit  
The simplest solution for maintenance and enables inverse rotation of the pump The splash ring protects the drive shaft against corrosion, further easing maintenance

## VERSION AND OPTION

### Casing material

**Base materials:**  
AISI 304, AISI 316

### Materials of the sealing shaft

**Base materials:**  
AISI 304, AISI 316

### Rotor materials

**Base materials:**  
AISI 420, AISI 304, AISI 316

### Heat treatments:

Hardening induction (only on AISI 420)

### Coatings:

Hardened Chrome plated HCP  
Chrome oxide plasma (ceramic coating)

### Stator materials

**Base materials:**  
NBR, food grade NBR, white NBR food grade  
EPDM, EPDM food grade, white EPDM food grade  
FPM, FPM food grade  
HNBR, HNBR food grade  
SYLICON  
Buna-N (available on select models on request)  
HYPALON (available on select models on request)  
PTFE (available on select models on request)

### Base plates

standard Base  
Base with anti-vibration housing (hygienic machine feet)  
Base with risers  
Skid with lifting devices  
Cart for industrial sector (trolley)  
Cart for food grade and winery sector  
(For details, see the brochure constructive options, equipment and installations)

### Connections

DIN 11851  
DIN 11864-1 / DIN 11864-2 / DIN 11864-3  
Clamp ISO 2852, Clamp ASME-3A, Clamp DIN 32676  
Flange UNI 2278 PN16 for pumps at 1 and 2 stage  
Flange UNI 2284 or 6084 PN40 for outlet unions for pumps at 4 stage  
Flange UNI 2285 PN64 for outlet unions for pumps at 8 stage  
Flange ASME B16.5 #150 for pumps at 1 and 2 stage  
Flange ASME B16.5 #300 for outlet unions for pumps at 4 and 8 stage  
RJT  
SMS 1145  
Garolla  
Macon

## FEATURES OF USE

### Operating range

#### Flow

Up to 140 m<sup>3</sup>/h

#### Pressure

Up to 24 bar for the standard series (48 bar for the series K8)

#### Temperature

from -40°C until to 150°C

### Sealing system

Gland packing seal B01  
Gland seal with flushing B02 (flushing system required)  
Single internal mechanical seal AK9  
Single external mechanical seal E019  
Single mechanical seal with Quench FK9 (buffer-Quench-pot required)  
Back-to-back double mechanical seal B1X9 (pressurized flushing system required)  
Tandem double mechanical seal T1X9 (buffer / flushing system required)  
(For construction details, see the brochure sealing systems and seals)

### Optional for coupling rod

Joint Protector (only on DXC series)  
Coupling rod with feed screw  
Antisettling impeller  
Balanced hydraulic joint (only on DXC series)  
(For details, see the brochure constructive options, equipment and installations)

### Protection devices

Temperature probe for dry running protection (standard in the ATEX version)  
Flow switch  
Pressure switch  
Flanged overpressure valve  
Hygienic overpressure valve  
(For details, see the brochure constructive options, equipment and installations)

### Control devices

Control panel  
Control panel with inverter  
Drive with integrated inverter  
(For details, see the brochure constructive options, equipment and installations)

### Equipment and optional

Stator heating jacket  
Heating jacket for body pump  
Stainless steel stator cover  
Grinder  
CIP Connection integrated on the body pump  
Integrated Bypass in the pump construction  
Quench Pot flushing  
Lantern in stainless steel  
Hermetic Lantern  
Carter to protect the motorization  
(For details, see the brochure constructive options, equipment and installations)

### Certifications

CE  
ATEX

### Typical applications

Enology, wine transfer  
Milk and dairy  
Sugar industry  
Beverages industry  
Breweries  
Distilleries  
Tomato industry

**TABLE OF MODELS**
**Flow and pressure**

Size	Model	Qmax 2 bar [m³/h]	rpm max	P max [bar]
<b>D020</b>	1L1	4,9	1400	6
	05K2	2,5	1400	12
	025K4	0,7	800	24
<b>D025</b>	2L1	10	1400	6
	1K2	5,1	1400	12
	05K4	1,5	800	24
	025K8	0,7	800	48
<b>D030</b>	4L1	14	1000	6
	2K2	7,2	1000	12
	1K4	2,9	800	24
	05K8	1,5	800	48
<b>D040</b>	10L1	22	800	6
	4K2	11,5	800	12
	2K4	4,2	600	24
	1K8	2,4	800	48
	16L1	32,5	800	6
	8K2	16,8	800	12
	4K2EL	11,5	800	18
<b>D060</b>	20L1	39,1	700	6
	10K2	17,2	600	12
	4K4	7,2	500	24
	2K8	4,2	600	48
	30L1	46	700	6
	16K2	21,5	600	12
	10K2EL	17,2	600	18
<b>D120</b>	40L1	65,5	600	6
	20K2	31	600	12
	10K4	11,7	400	24
	4K8	7,3	500	48
	60L1	82	500	6
	30K2	40,5	500	12
	20K2EL	31	600	18
<b>D300</b>	80L1	88	400	6
	40K2	45	400	12
	20K4	21	400	24
	10K8	11,7	400	48
	120L1	120	400	6
	60K2	64,5	400	12
	40K2EL	45	400	18



Via Carlo Cattaneo, 19/25  
36040 SOSSANO (VI)  
ITALY

Phone: +39-0444-888151  
Fax: +39-0444-888152  
E-Mail: [sales@novarotors.com](mailto:sales@novarotors.com)  
Web site: [www.novarotors.com](http://www.novarotors.com)

